



**REQUEST FOR QUOTATION
NP- SMALL VALUE PROCUREMENT**

RFQ No. : DSWD7-2024-1102

Date : August 22, 2024

Company Name : _____

Company Address : _____

Contact Person : _____

Contact No. : _____

PhilGEPS Registration No.: _____

Sir/Madam:

Please quote your government price/s including delivery charges, VAT or other applicable taxes, and other incidental expenses for the goods listed in Annex A. Failure to indicate information could be the basis for non-compliance. Also, kindly furnish us with descriptive brochures, catalogues, literatures and/or samples, if applicable.

If you are the exclusive manufacturer, distributor or agent in the Philippines for the goods listed in **Annex A**, please attach in your quotation a duly notarized certification to this effect.

Interested supplier/s are required to submit true copies of their **valid Mayor's Permit, Philgeps Registration Number** upon submission of quotation/s.

Please accomplish and submit this **form** together with **Annex A** and **Bank Information** to the BAC Secretariat, DSWD Field Office VII, Cebu City or send it through facsimile numbers (032) 233-8785; 233-0261; 231-2172 local 140 or 148 or e-mail to bac.fo7@dswd.gov.ph on or before **August 27, 2024 at 5:00PM.**

Very truly yours,

ENGR. EMMANUEL M. EDLES
AO V/Head, Procurement Management Section

Terms and Conditions:

- Award shall be made on per: item basis total quoted price lot basis
- Quotation validity shall be not less than **60 calendar days.**
- Good/s or Services shall be delivered **please refer to Annex A**
- Place of Delivery: **Home for Girls, Camomot Franza Rd., Brgy Labangon, Cebu City**
- Terms of Payment: **within 30 days from the receipt of billing statement.**
- Liquidated Damages/Penalty: **One-tenth of one percent for everyday of delay shall be imposed.**
- In case of discrepancy between total price per item and unit price for the item as extended or multiplied by the quantity of that item, the latter shall prevail.
- Warranty period, if applicable: _____

CHAR ALBERT J. TORREFIEL
Canvasser

I am interested to quote and agree to the terms and conditions.

(Signature over Printed Name of Supplier / Service
Provider / Authorized Representative)



DEPARTMENT OF SOCIAL WELFARE AND DEVELOPMENT
Field Office VII, Cebu City

Company Name _____
 Company Address _____
 Contact Person _____
 Contact No. _____
 PhilGEPS Registration No.: _____
 Tin Number: _____

RFQ No. **DSWD7-2024-1102**
 Date: **August 22, 2024**

Item No.	Quantity	Unit of Measure	Articles / Descriptions	Statement of Compliance (State "Comply" or "Not Comply")	Bidder's Specifications	Unit Cost	Total Cost
Supply and Delivery of Customized Cabinet							
1	3	piece	Cabinet, customized, for long case folders, 100cm x 35cm x 200cm H, laminated 3/4 marine plywood, in wood grain finish, hardware in concealed hinges and door handle, with cam lock				
2	4	piece	Cabinet, customized, closet 95cm x 55cm x 185cm H, laminated 3/4 marine plywood, in wood grain finish, hardware in concealed hinges and door handle, with hanger tubes (please see attached picture with dimensions and specifications)				
Total:							
Approved Budget for the Contract: Php 105,000.00				Note:			
End User: HFG				"Bidder's Specifications" column may be filled up with service provider or may copy "Articles/Description" stated if applicable.			
PURPOSE : For Home for Girls' linen, active case folders, office supplies and materials storage.							

Note: Procurement procedure in accordance with DSWD-Memorandum Circular No. 2, Series of 2007.

CHARL ALBERT J. TORREFIEL
 Canvasser

Signature of Supplier / Authorized Representative Over
 Printed Name

(page 2 of 2)

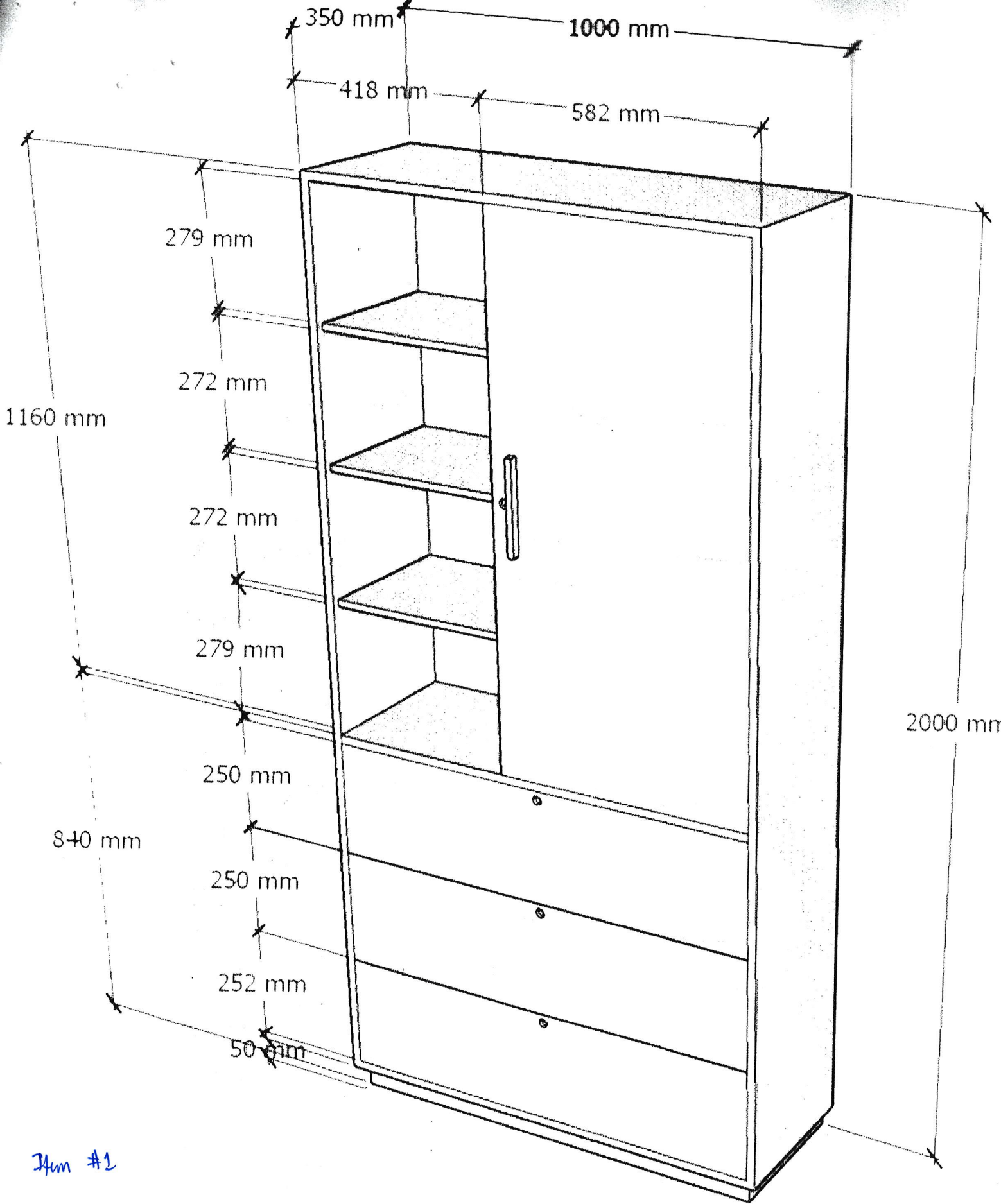

Item #1

550 mm 960 mm

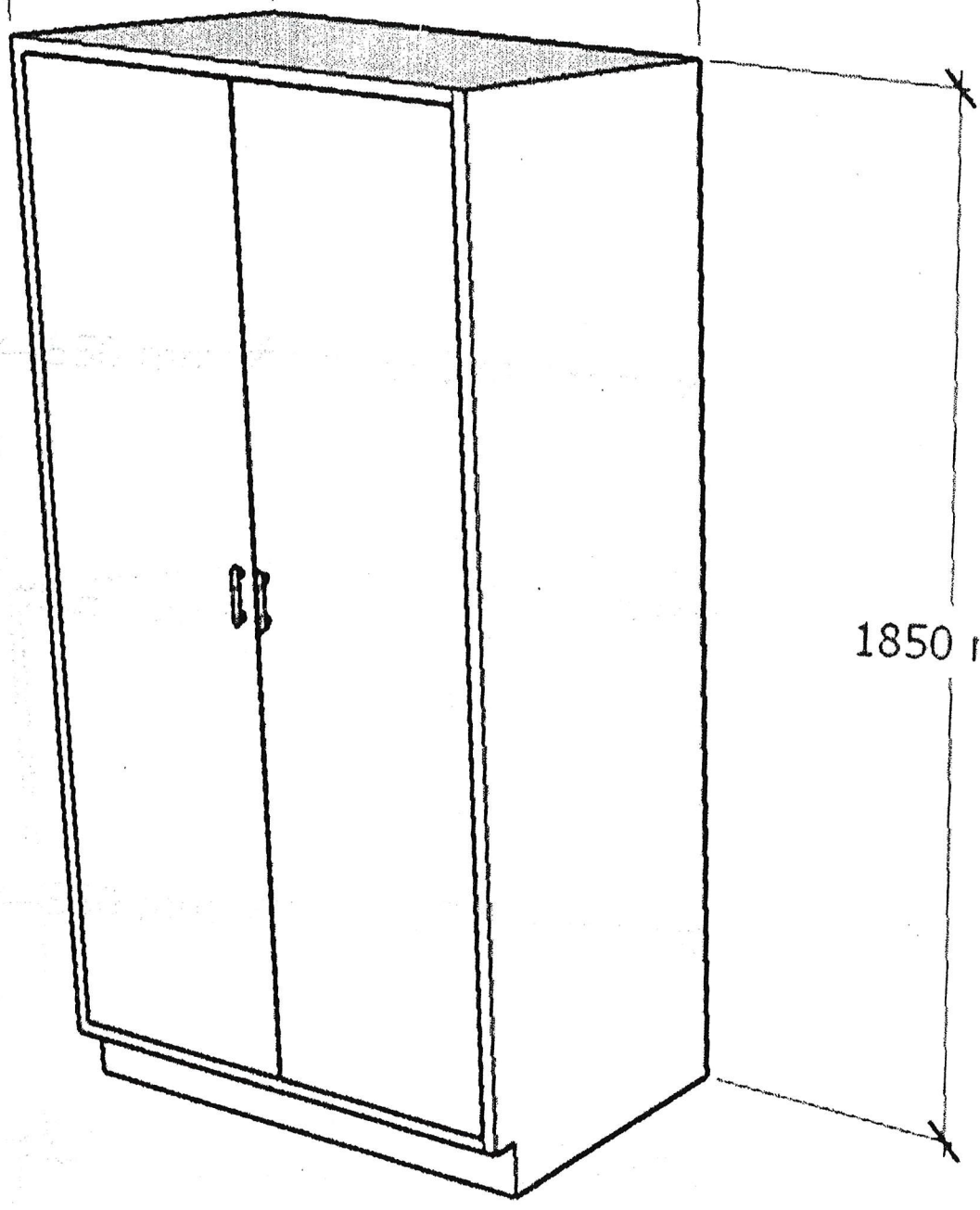

1850 mm

Item #2